



DATA SHEET :ACI-88-252LA



Model 252 AC Isolator:

Description:

The PDC Model ACI-88 dual channel AC isolator is designed specifically to meet the California Department of Transportation, Model 252 specifications. Each channel of the Model 252 shall present a true signal (ground closure) at the output of its optical coupling device when a AC signal of +80 +/-5 VAC is applied to its receptive input for a period of 100 milliseconds. Each channel is provided with switches, which will invert the output signals. When the switch for a channel is set to invert, the respective channel will maintain a true output (ground closure) until a voltage of +80 +/-5 VAC is applied for a minimum of 100 milliseconds at which time the respective output will go false. A transition from false to true will occur when the respective input voltage drops to 70 volts for 100 milliseconds.

All electronics are provided on a single sided P.C. board with an aluminum front panel. The P.C. board is provided with a solder mask, silk screen identifying all component locations and is conformally coated to resist adverse environmental conditions. Switch programming is done with solid jumpers at S3 not dip switches.

Installation:

The Model 252 AC Isolator intermates with the appropriate traffic signal control or traffic management system cabinet input file. Connector pinouts are shown in Fig. 1. The connector mates with a Cinch #250-22-30-xxx or equivalent.

Pin	Function	Pin	Function
A	DC ground	N	AC+
B	+24 VDC	P	NA
C	NA	R	NA
D	Input #1	S	NA
E	Input #1 common	T	NA
F	Output #1 (C)	U	NA
H	Output #1 (E)	V	NA
J	Input #2	W	Output #2 (C)
K	Input #2 common	X	Output #2 (E)
L	Equipment ground	Y	NA
M	AC-	Z	NA

FIG 1.

General Characteristics: Model ACI-88-252

Input:	Voltage	135 VAC
	True State	80 +/-3 VAC, 100 msec.
	False State	70 +/-3 VAC, 100 msec.
Output:	Voltage	30 VDC max.(open collector)
	Current	50 mamp sink(true state)
Power:	Voltage	+24 VDC
	Current	100 mamp max.
Isolation:	Voltage	2500 VAC
	Resistance	1000 megohm.
Transient suppression:	Energy	50 Joules
Mechanical:	Length	7.00 IN.
	Width	1.12 IN.
	Height	4.50 IN.
	Weight	0.35 LBS

Alignment procedure: There is no alignment procedure required for the operation of the AC Isolator.

Adjustments: Input Voltage level pots are factory set for 80 and 70 volts.



DATA SHEET :ACI-88-252LA



Theory of Operations:

General:

The AC Voltage is applied to the input circuit, consisting of a transient suppresser, full wave bridge, and resistive voltage divider. Refer to Fig. 2. The input circuit resistive divider presents a full wave rectified signal to the diode primary of the optical couplers. The resistive dividers are calculated such that the threshold of the optical coupler is reached when the input voltage is approximately 70 and 80 volts respectively. If the input voltage exceeds 80 VAC the secondary of the optical coupler will trigger the 100 Msec. timer. Assuming the input remains the 100 Msec. timer will time out and set the valid input signal latch. The latch in turn drives the output opticalcoupler turning on the output transistor. If the input voltage falls below 70 VAC the secondary input optical coupler turns off triggering a 100 Msec. timer. If this condition exists for 100 Msec. the valid input signal latch reset turning off the output transistor. Any time the input voltage exceeds the threshold of the input optical coupler during this period the 100 Msec. timer will be reset.

Detailed Circuit Description:

Refer to circuit schematic, Fig. 3. Power and a DC reference for all circuits is derived from the combination of R17 and CR3 driven by the external 24 VDC power supply. Let's consider channel 1 only, with AC input on pins D & E and output on pins H & F. Assume A voltage greater than 80 VAC is applied to the input. This voltage is rectified by CR1 and applied to resistor string R2, R3, R4 and R5. R3 has been set so that at 80 VAC the diode of the input coupler U1 will be saturated, creating a low signal at the collector of the output transistor (U1). This low signal will discharge capacitor C1 and produce a low signal at U5-2. R5 has been set so that at 70 VAC the diode of the input coupler U2 will be saturated, creating a low signal at the collector of the output transistor (U2). The low signal U5-2 will then create a high transition at output U2-3. Triggering the 100 Msec. one shot (U6-4). After the one shot (U6) times out latch (U8) will be clocked and will lock in an output signal to Q1 which will cause a true output on channel 1. When the input voltage goes below 70 VAC the output collector of U2 will remain high. This high will appear on U5-12,13 causing U5-11 to go low. Triggering the 100 Msec. (U6-11). If the input stays below 70 VAC in excess of 100 Msec. U6 will time out resetting latch U8and causing the output from channel 1 to go false.

Channel 2 may be analyzed in an identical manner to channel 1.

Maintenance:

Preventive maintenance: The AC isolator may be stored in any non-corrosive environment until needed. Once installed and operating the isolator needs no preventive maintenance during normal operation.



DATA SHEET :ACI-88-252LA



Troubleshooting:

Should improper operation of the Isolation module be observed, the technician should first become thoroughly familiar with the theory of operation before attempting to troubleshoot. Refer to isolation schematic, Fig 3 and Fig 4 for component location. Proceed with the following paragraphs to isolate the component problem.

Trouble shooting sequence chart:

Problem	Solution
A) No Output	Verify input voltage <85 VAC Verify +24 VDC pin B input file Go to trouble shooting problem 1.
B) False Outputs	Verify input voltage <85 VAC Check 12 VDC CR3 Cathode Check 100 Msec timers U6, U7
C) Output Always On	Verify input voltage >65 VAC Go to problem 2.

Preliminary checks and voltage measurements:

1. Check for cabinet +24 VDC at pin B, ground at pin A.
2. Check AC inputs at pins D,E,J, and K. Check for proper voltage levels.
3. Check output connections and proper loading.

If the preliminary checks 1 thru 4 are normal, then the problem must be within the AC Isolation Module. Select problems 1 or 2 depending on the fault condition present. The isolation procedures shown assume channel 1 of the module to be faulty.

Problem 1.

With >80 VAC applied, the output does not go true (Saturated NPN transistor, pins H and F).

1. Verify that >80 VAC is applied to channel 1 input, pins D and E. Does indicator I1 illuminate? If no go to 2A. If yes replace Q2. If this does not correct the problem then replace optical isolation U9.
- 2A. Depress test switch S1. Does I1 illuminate? If yes go to 3.
- B. Short collector Q1 to ground. Does I1 illuminate? If yes go to 3.
- C. Short across anode and cathode of I1. Does output go true? If yes replace I1. If no replace Q2. If this does not correct the problem then replace optical isolator U9.
3. Check state of U8-1. If low go to 4A. If high (11-12 VDC) , check continuity from U8-1 to base of Q1.
- 4A. Check state of U8-2. If high proceed to 4B.If high proceed to 4B. If low replace U8 note that the problem could also be a shorted input at U5.
- B. Check state of U8-4. If high go to 11. If low proceed to 5A.
- 5A. Check signal at U1-1. If signal is as inFig. 5A, the proceed to 6A.
- B. If signal is half wave rectified replace diode bridge CR1.
- C. If no signal is present at U1-1, then measure signal at + terminal of CR1. If no signal at this point, replace CR1. If full wave rectified signal at this point,replace U1. Check continuity to U1-1.



DATA SHEET :ACI-88-252LA



- 6A. Check signal at U1-5. If signal is as in Fig. 5C, then proceed to 7A.
- B. If the signal is 12 VDC then replace U1.
- C. If the signal is 0 VDC remove one leg of C1. If signal becomes a square wave replace C1. If not replace U2.
- 7A. Check signal at U2-5. If signal is as in Fig. 5B then proceed to 8.
- B. If signal is 12 VDC replace U2.
- C. If signal is 0 VDC replace U2.
- 8. Check U5-3. If high proceed to 9. If low replace U5.
- 9. Remove input voltage. If U5-3 goes low then proceed to 10. If not replace U5.
- 10. Observe U6-7. Re-apply >70 to channel 1 input. Signal shall go low for 100 Msec. and then high. If this occurs, replace U6, otherwise replace U5.
- 11. Check U5-11. Signal should be a square wave. If yes replace U6. If no replace U5.

Problem 2.

Output goes true with greater than 80 VAC, however will not go false if input drops below 70 VAC.

- 1. With output true and input below 70 VAC does indicator I1 illuminate. If yes proceed to 2. If no replace Q2. If this does not correct the problem then replace U9.
- 2. Check U8-1. If high proceed to 3. If low replace Q1.
- 3. Check U8-4. If low replace U6. If high replace U8.

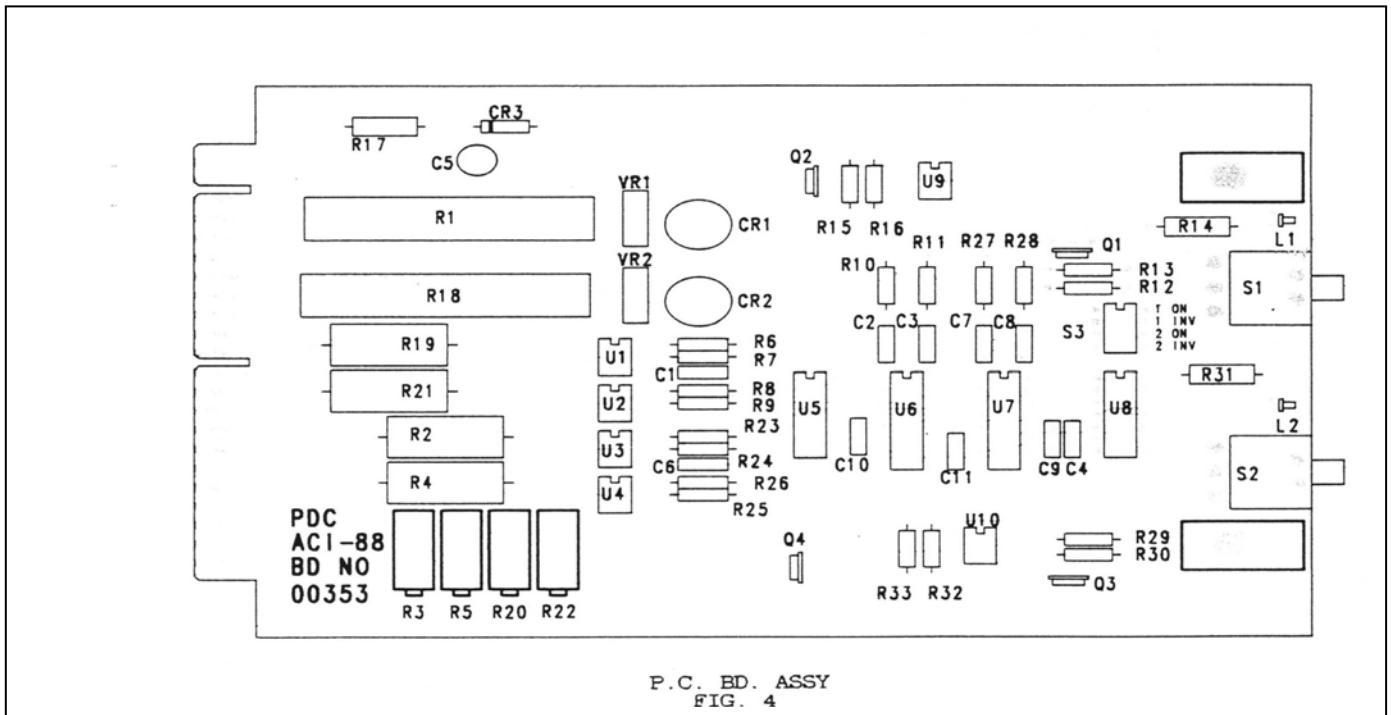

			ACI-88-252 PARTS LIST	ASSY #00353		
Item	Qty	PDC P/N	Description	MFG.	MFG P/N	Ref Des.
1	1	00353	PC Board Fab.	PDC	00353	

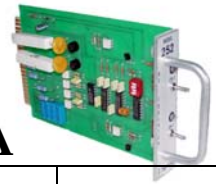

DATA SHEET :ACI-88-252LA

2	1	00118	Front Label	PDC	00118	
3	1	00134-1	Label	PDC	00134-1	
4	1	00333-2	Handle	PDC	00333-2	
5	2	H0012	Angle bracket	G&C	6263	
6	2	S0002	Switch	C&K	7107SD9ABE	S1,S2
7	2	LD0004	L.E.D.	Monsanto	MV5020	I1,I2
8	6	IC0001	Opto Isolator	Motorola	4N25	U1,U2,U3, U4,U9,U10
9	1	IC0009	C-Mos 4013B	Motorola	MC14013B	U8
10	1	IC0008	C-Mos 4093B	Motorola	MC14093B	U5
11	2	IC0013	C-Mos 4098B	Motorola	MC14098B	U6,U7
12	1	CR0005	Diode, Zener	Fairchild	1N759	CR3
13	2	CR0004	Diode, Zener	G.I.	WL06M	CR1,CR2
14	4	Q0004	Transistor	G.E.	2N4401	Q1,Q2,Q3,Q4
15	2	VR0001	Varistor	Panasonic	10DK241	VR1,VR2
16	4	R0066	Potentiomete	Beckman	EDN- K0AAO0B22	R3,R5,R20,R22
17	2	R0028	Res. 5 ohm 10W 10%	Dale		R1,R18
18	4	R0034	Res. 13K 2W 5%	Dale		R2,R4,R19,R21
19	1	R0025	Res. 680 ohm 1/2W 5%	Dale		R17
20	10	R0022	Res. 390K ohm 1/4W 5%	Dale		R6-9,R23- 26,R15,R32
21	4	R0024	Res. 3.3M ohm 1/4W 5%	Dale		R10,R11,R27,R28
22	2	R0020	Res. 150K ohm 1/4W 5%	Dale		R16,R33
23	2	R0007	Res. 1K ohm 1/2W 5%	Dale		R14,R31
24	2	R0014	Res. 12K ohm 1/4W 5%	Dale		R12,R29
25	2	R0016	Res. 27K ohm 1/4W 5%	Dale		R13,R30
26	1	C0005	Cap. 22mf 35V	Sprague		C5
27	8	C0008	Cap. 0.1mf 50V 10%	Sprague		C1-3,C6- 8,C10,C11
28	2	C0013	Cap. 1000pf 500V 10%	Thomson CSF		C4,C9
29	2		Screw, PH PAN HD 4-40 x 5/16			
30	2		Nut, Hex, Keps 4-40			
31	2		Washer, split #4			
32	2		Screw, self tapping #6			